

THIS DRAWING IS UNPUBLISHED. RELEASED FOR PUBLICATION
 © COPYRIGHT BY TYCO ELECTRONICS CORPORATION. ALL RIGHTS RESERVED.

LOC	DIST	REVISIONS					
		P	LTR	DESCRIPTION	DATE	DWN	APVD
G	86		K	REDRAWN PER 0G3A-0400-04	02JUN04	JR	MS

- 1 TONGUE MATERIAL THICKNESS .045±.003
- △ 2 BODY: COPPER PER ASTM B-152
TIN PER ASTM B-545
INSULATION: PVC, COLOR - BLUE
METALLIC SLEEVE: COPPER PER ASTM B-152
METALLIC BAND: STEEL PER ASTM A109
- 3 FOR .377 MAX WIRE INSULATION DIA

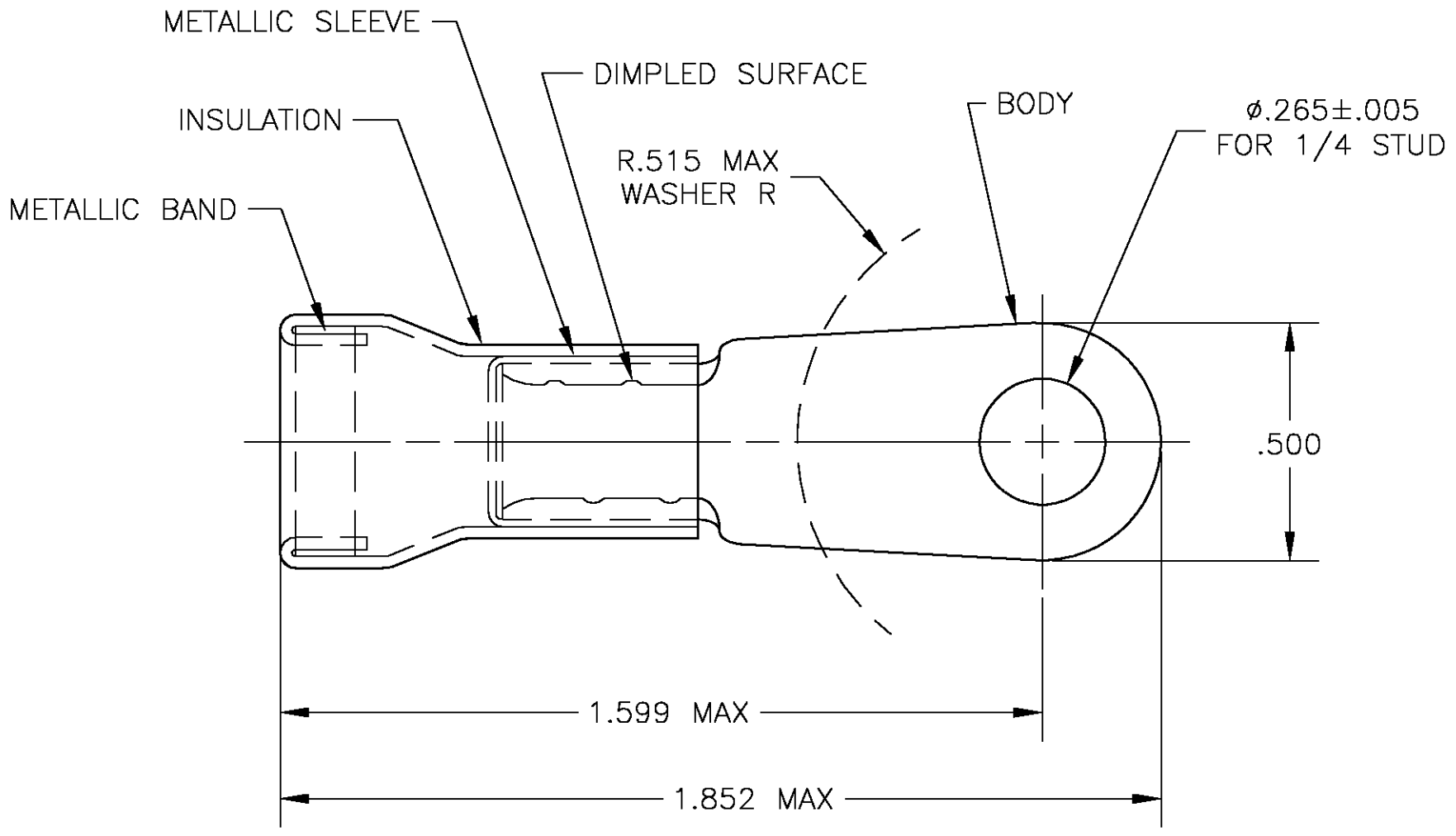

P/N ON TAPE	QTY	DESCRIPTION	PART NO
2-322051-2	1	WIRE TERMINAL	322051

THIS DRAWING IS A CONTROLLED DOCUMENT.		DWN jr_ruth 02JUN04	Tyco Electronics Corporation Harrisburg, PA 17105	
DIMENSIONS: INCHES		CHK MJ SPICER 02JUN04		
		APVD MJ SPICER 02JUN04	NAME TERMINAL, AMPLI-BOND, RING TONGUE WIRE SIZE: 6	
TOLERANCES UNLESS OTHERWISE SPECIFIED:		PRODUCT SPEC	RESTRICTED TO	
0 PLC ± -		APPLICATION SPEC	SIZE	CAGE CODE
1 PLC ± -		WEIGHT	A3	00779
2 PLC ± -		DRAWING NO		322051
3 PLC ± .008		CUSTOMER DRAWING		SCALE 3:1
4 PLC ± -		SHEET 1 OF 1		REV K
ANGLES ± 5'		FINISH		
- △ 2				